



Cambridge IGCSE™

CANDIDATE
NAME

CENTRE
NUMBER

--	--	--	--	--

CANDIDATE
NUMBER

--	--	--	--

MATHEMATICS

0580/42

Paper 4 (Extended)

February/March 2020

2 hours 30 minutes

You must answer on the question paper.

You will need: Geometrical instruments

INSTRUCTIONS

- Answer **all** questions.
- Use a black or dark blue pen. You may use an HB pencil for any diagrams or graphs.
- Write your name, centre number and candidate number in the boxes at the top of the page.
- Write your answer to each question in the space provided.
- Do **not** use an erasable pen or correction fluid.
- Do **not** write on any bar codes.
- You should use a calculator where appropriate.
- You may use tracing paper.
- You must show all necessary working clearly.
- Give non-exact numerical answers correct to 3 significant figures, or 1 decimal place for angles in degrees, unless a different level of accuracy is specified in the question.
- For π , use either your calculator value or 3.142.

INFORMATION

- The total mark for this paper is 130.
- The number of marks for each question or part question is shown in brackets [].

This document has **20** pages. Blank pages are indicated.



1 Dhanu has a model railway.

- (a) He has a train that consists of a locomotive and 4 coaches.
The mass of the locomotive is 87 g and the mass of each coach is 52 g.

(i) Work out the total mass of the train.

..... g [2]

(ii) Work out the mass of the locomotive as a percentage of the total mass of the train.

..... % [1]

- (b) The train is 61 cm long and travels at a speed of 18 cm/s.
It takes 4 seconds for the whole of the train to cross a bridge.

Calculate the length of the bridge.

..... cm [2]

- (c) A new locomotive costs \$64.

Calculate the cost of the locomotive in rupees when the exchange rate is 1 rupee = \$0.0154 .
Give your answer correct to the nearest 10 rupees.

..... rupees [2]

3

- (d) The cost of a railway magazine increases by 12.5% to \$2.70 .

Calculate the cost of the magazine before this increase.

\$ [2]

- (e) Dhanu plays with his model railway from 06 50 to 11 15.
He then rides his bicycle for 3 hours.

Find the ratio time playing with model railway : time riding bicycle.
Give your answer in its simplest form.

..... : [3]

- (f) The value of Dhanu's model railway is \$550.
This value increases exponentially at a rate of $r\%$ per year.
At the end of 5 years the value will be \$736.

Calculate the value of r .

$r =$ [3]

2 (a) The table shows some values for $y = 2x^3 - 4x^2 + 3$.

x	-1	-0.5	0	0.5	1	1.5	2
y	-3	1.75				0.75	3

- (i) Complete the table. [3]
- (ii) On the grid, draw the graph of $y = 2x^3 - 4x^2 + 3$ for $-1 \leq x \leq 2$.

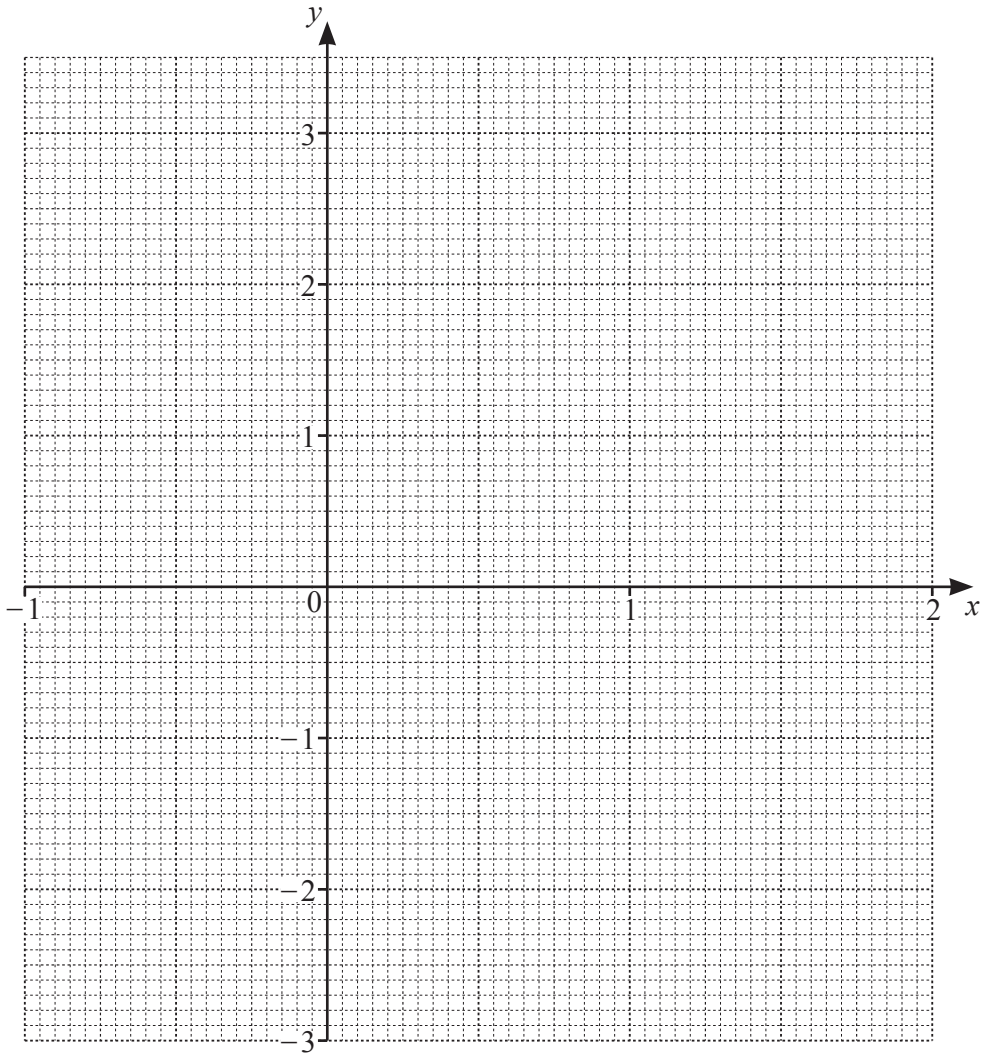

[4]

(iii) Use your graph to solve the equation $2x^3 - 4x^2 + 3 = 1.5$.

$x = \dots\dots\dots$ or $x = \dots\dots\dots$ or $x = \dots\dots\dots$ [3]

(iv) The equation $2x^3 - 4x^2 + 3 = k$ has only one solution for $-1 \leq x \leq 2$.

Write down a possible integer value of k .

$\dots\dots\dots$ [1]

(b)

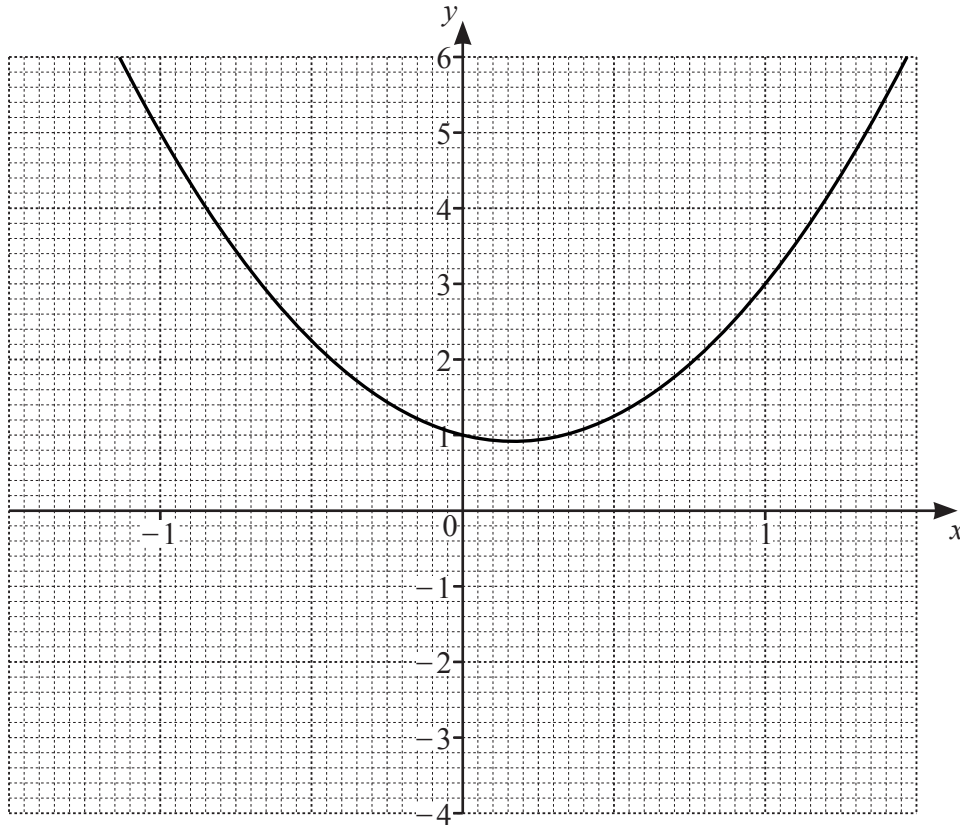

(i) On the grid, draw the tangent to the curve at $x = 1$. [1]

(ii) Use your tangent to estimate the gradient of the curve at $x = 1$.

..... [2]

(iii) Write down the equation of your tangent in the form $y = mx + c$.

$y =$ [2]

- 3 (a) Manjeet uses 220 litres of water each day.
She reduces the amount of water she uses by 15%.

Calculate the number of litres of water she now uses each day.

..... litres [2]

- (b) Manjeet has two mathematically similar bottles in her bathroom.
The large bottle holds 1.35 litres and is 29.7 cm high.
The small bottle holds 0.4 litres.

Calculate the height of the small bottle.

..... cm [3]

- (c) Water from Manjeet's shower flows at a rate of 12 litres per minute.
The water from the shower flows into a tank that is a cuboid of length 90 cm and width 75 cm.

Calculate the increase in the level of water in the tank when the shower is used for 7 minutes.

..... cm [3]

4 A solid metal cone has radius 1.65 cm and slant height 4.70 cm.

(a) Calculate the **total** surface area of the cone.

[The curved surface area, A , of a cone with radius r and slant height l is $A = \pi r l$.]

..... cm² [2]

(b) Find the angle the slant height makes with the base of the cone.

..... [2]

(c) (i) Calculate the volume of the cone.

[The volume, V , of a cone with radius r and height h is $V = \frac{1}{3}\pi r^2 h$.]

..... cm³ [4]

(ii) A metal sphere with radius 5 cm is melted down to make cones identical to this one.

Calculate the number of complete identical cones that are made.

[The volume, V , of a sphere with radius r is $V = \frac{4}{3}\pi r^3$.]

..... [4]

5 (a) Write as a single fraction in its simplest form.

$$\frac{x+3}{x-3} - \frac{x-2}{x+2}$$

..... [4]

(b) $2^{12} \div 2^{\frac{k}{2}} = 32$

Find the value of k .

$k =$ [2]

(c) Expand and simplify.

$$(y + 3)(y - 4)(2y - 1)$$

..... [3]

(d) Make x the subject of the formula.

$$x = \frac{3 + x}{y}$$

$x =$ [3]

6 Suleika has six cards numbered 1 to 6.

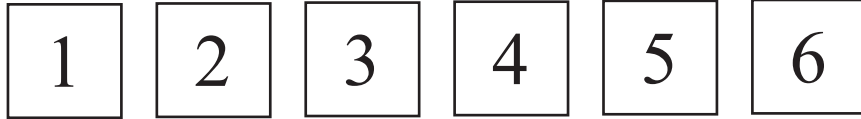

(a) She takes one card at random, records the number and replaces the card.

(i) Write down the probability that the number is 5 or 6.

..... [1]

(ii) Suleika does this 300 times.

Find how many times she expects the number 5 or 6.

..... [1]

(b) Suleika takes two cards at random, without replacement.

(i) Find the probability that the sum of the numbers on the two cards is 5.

..... [3]

(ii) Find the probability that at least one of the numbers on the cards is a square number.

..... [3]

- 7 (a) Naga has n marbles.
 Panav has three times as many marbles as Naga.
 Naga loses 5 marbles and Panav buys 10 marbles.
 Together they now have more than 105 marbles.

Write down and solve an inequality in n .

..... [3]

- (b) y is inversely proportional to x^2 .
 When $x = 4$, $y = 7.5$.

Find y when $x = 5$.

$y =$ [3]

- (c) Find the n th term of each sequence.

- (i) 4 2 0 -2 -4 ...

..... [2]

- (ii) 1 7 17 31 49 ...

..... [2]

8 (a)

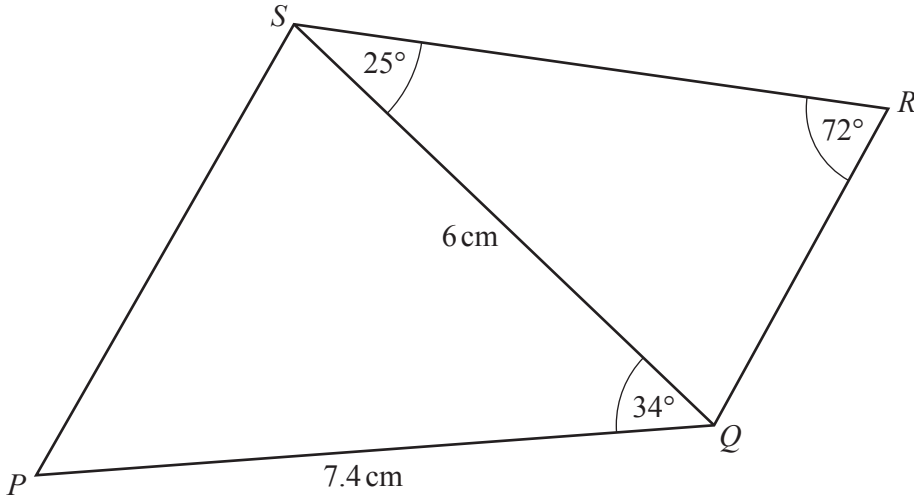

NOT TO SCALE

The diagram shows a quadrilateral $PQRS$ formed from two triangles, PQS and QRS .

Calculate

(i) QR ,

$QR = \dots\dots\dots \text{ cm [3]}$

(ii) PS ,

$PS = \dots\dots\dots \text{ cm [3]}$

(iii) the area of quadrilateral $PQRS$.

$\dots\dots\dots \text{ cm}^2 \text{ [4]}$

(b)

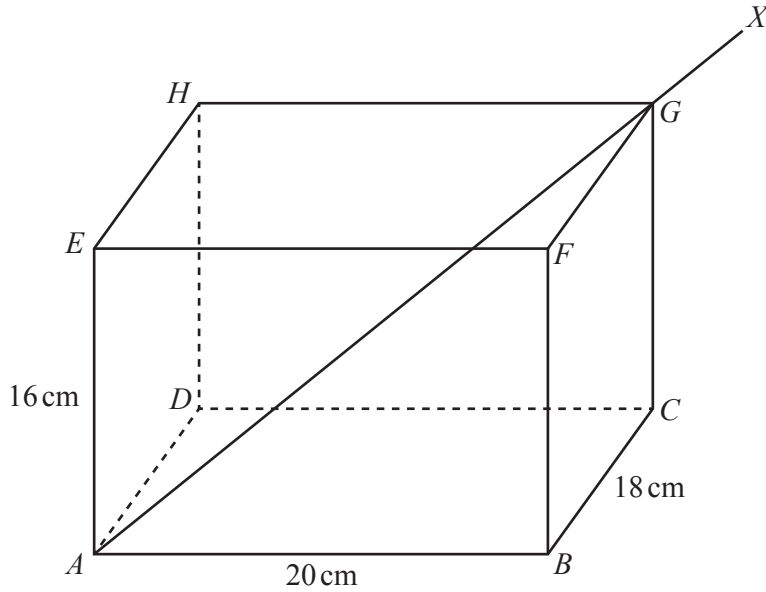

NOT TO SCALE

The diagram shows an open box $ABCDEFGH$ in the shape of a cuboid.
 $AB = 20$ cm, $BC = 18$ cm and $AE = 16$ cm.
 A thin rod AGX rests partly in the box as shown.
 The rod is 40 cm long.

(i) Calculate GX , the length of the rod which is outside the box.

$GX = \dots\dots\dots$ cm [4]

(ii) Calculate the angle the rod makes with the base of the box.

$\dots\dots\dots$ [3]

9 This year, 40 students have each travelled by one or more of plane (P), train (T) or boat (B).

- 7 have travelled only by plane.
- 11 have travelled only by train.
- 9 have travelled only by boat.

$$n(P \cap T) = 8$$

$$n(B \cap T) = 3$$

$$n(B \cap P) = 6$$

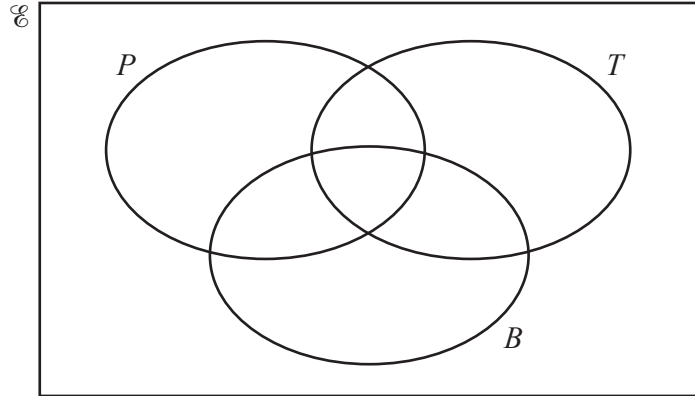

(a) Complete the Venn diagram. [3]

(b) Find $n((P \cup B)')$.

..... [1]

(c) Use set notation to complete the statement.

$(P \cup T \cup B)' = \dots\dots\dots$ [1]

- (d) Two students are chosen at random.

Calculate the probability that they both have travelled only by plane.

..... [2]

- (e) Two students are chosen at random from those who have travelled by train.

Calculate the probability that they both have also travelled by plane.

..... [2]

10

$f(x) = 4x - 1$

$g(x) = x^2$

$h(x) = 3^{-x}$

(a) Find in its simplest form

(i) $f(x - 3)$,

..... [1]

(ii) $g(5x)$.

..... [1]

(b) Find $f^{-1}(x)$.

$f^{-1}(x) =$ [2]

(c) Find the value of $hh(1)$, correct to 4 significant figures.

..... [3]

(d) (i) Show that $g(3x-2) - h(-3)$ can be written as $9x^2 - 12x - 23$.

[2]

(ii) Use the quadratic formula to solve $9x^2 - 12x - 23 = 0$.
Give your answers correct to 2 decimal places.

$x = \dots\dots\dots$ or $x = \dots\dots\dots$ [4]

(e) Find x when $f(61) = h(x)$.

$x = \dots\dots\dots$ [2]

11 A curve has equation $y = x^3 - 3x + 4$.

(a) Work out the coordinates of the two stationary points.

(..... ,)

(..... ,) [5]

(b) Determine whether each stationary point is a maximum or a minimum.
Give reasons for your answers.

[3]

BLANK PAGE

BLANK PAGE

Permission to reproduce items where third-party owned material protected by copyright is included has been sought and cleared where possible. Every reasonable effort has been made by the publisher (UCLES) to trace copyright holders, but if any items requiring clearance have unwittingly been included, the publisher will be pleased to make amends at the earliest possible opportunity.

To avoid the issue of disclosure of answer-related information to candidates, all copyright acknowledgements are reproduced online in the Cambridge Assessment International Education Copyright Acknowledgements Booklet. This is produced for each series of examinations and is freely available to download at www.cambridgeinternational.org after the live examination series.

Cambridge Assessment International Education is part of the Cambridge Assessment Group. Cambridge Assessment is the brand name of the University of Cambridge Local Examinations Syndicate (UCLES), which itself is a department of the University of Cambridge.