

**Cambridge IGCSE™**CANDIDATE  
NAMECENTRE  
NUMBER

--	--	--	--	--

CANDIDATE  
NUMBER

--	--	--	--

**MATHEMATICS****0580/32**

Paper 3 (Core)

**February/March 2024****2 hours**

You must answer on the question paper.

You will need: Geometrical instruments

**INSTRUCTIONS**

- Answer **all** questions.
- Use a black or dark blue pen. You may use an HB pencil for any diagrams or graphs.
- Write your name, centre number and candidate number in the boxes at the top of the page.
- Write your answer to each question in the space provided.
- Do **not** use an erasable pen or correction fluid.
- Do **not** write on any bar codes.
- You should use a calculator where appropriate.
- You may use tracing paper.
- You must show all necessary working clearly.
- Give non-exact numerical answers correct to 3 significant figures, or 1 decimal place for angles in degrees, unless a different level of accuracy is specified in the question.
- For  $\pi$ , use either your calculator value or 3.142.

**INFORMATION**

- The total mark for this paper is 104.
- The number of marks for each question or part question is shown in brackets [ ].

This document has **16** pages.

1 (a)

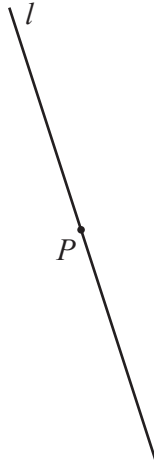

Draw a line through point  $P$  that is perpendicular to line  $l$ . [1]

(b) Write down the mathematical names for two different quadrilaterals with

- two lines of symmetry
- and**
- rotational symmetry of order two.

..... and ..... [2]

(c) The diagram shows a quadrilateral on a  $1\text{ cm}^2$  grid.

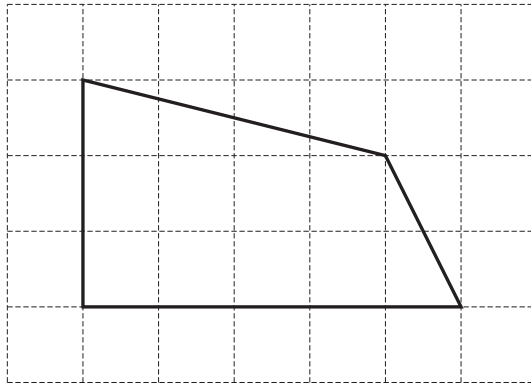

Find the area of this quadrilateral.

.....  $\text{cm}^2$  [1]

(d)

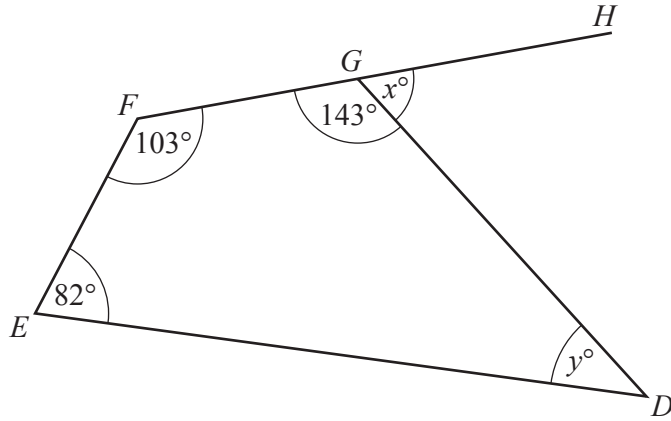

NOT TO SCALE

The diagram shows a quadrilateral  $DEFG$  and a straight line  $FGH$ .

(i) Angle  $DEF = 82^\circ$ .

Write down the mathematical name for this type of angle.

..... [1]

(ii) Work out the value of  $x$ .  
Give a geometrical reason for your answer.

$x =$  ..... because .....

..... [2]

(iii) Work out the value of  $y$ .  
Give a geometrical reason for your answer.

$y =$  ..... because .....

..... [2]

2 (a)

Fuel  
Garage A  
\$1.41 per litre

Fuel  
Garage B  
\$1.50 per litre

(i) Tiya buys 55 litres of fuel from garage A.

Work out the change she receives from \$100.

\$ ..... [2]

(ii) Work out how much cheaper it is to buy 20 litres of fuel from garage A than from garage B.

\$ ..... [2]

(iii) These are the amounts that 6 people spend on fuel at garage A.

\$63      \$84.50      \$72.23      \$46      \$54.10      \$80

Calculate the mean **number of litres** that they buy.

..... litres [3]

(iv) The cost of fuel at garage B increases from \$1.50 to \$1.53 .

Calculate the percentage increase.

..... % [2]

- (b) The fuel tank of a car is  $\frac{2}{5}$  full.  
It takes 39 more litres of fuel to fill the tank.

Work out the number of litres of fuel in a full tank.

..... litres [3]

- (c) (i) Use 1 litre = 0.22 gallons to complete this conversion graph.

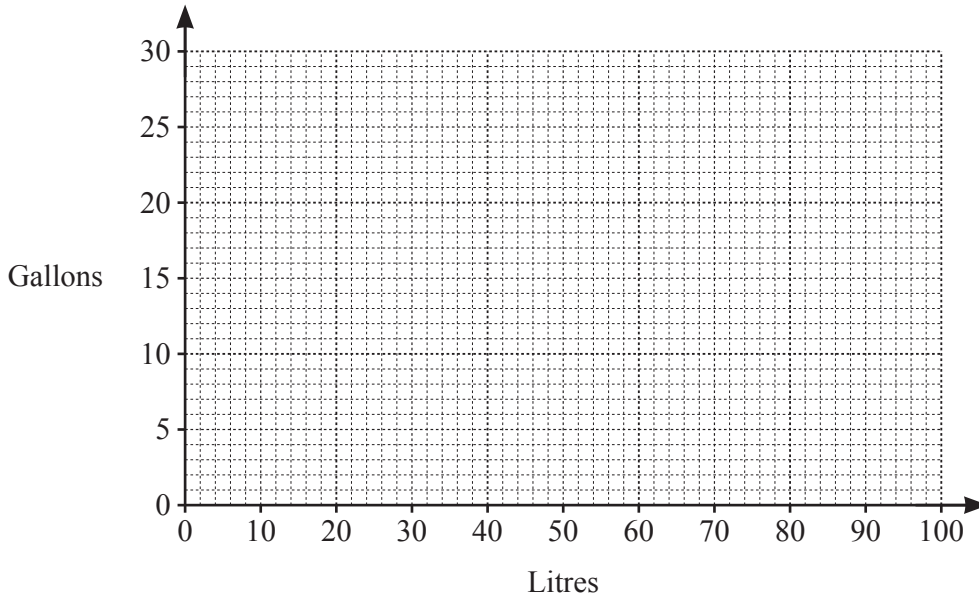

[2]

- (ii) Use 1 litre = 0.22 gallons to complete this statement.

1 gallon = ..... litres. [1]

- (d) A cylindrical tank for storing fuel has radius 1.5 metres and height 8 metres.

Calculate the volume of the tank **in litres**.

..... litres [3]

- 3 (a) In triangle  $DEF$ ,  $DE = 6\text{ cm}$  and  $DF = 4.8\text{ cm}$ .

Using a ruler and compasses only, construct triangle  $DEF$ .

Leave in your construction arcs.

The line  $EF$  has been drawn for you.



[2]

- (b)

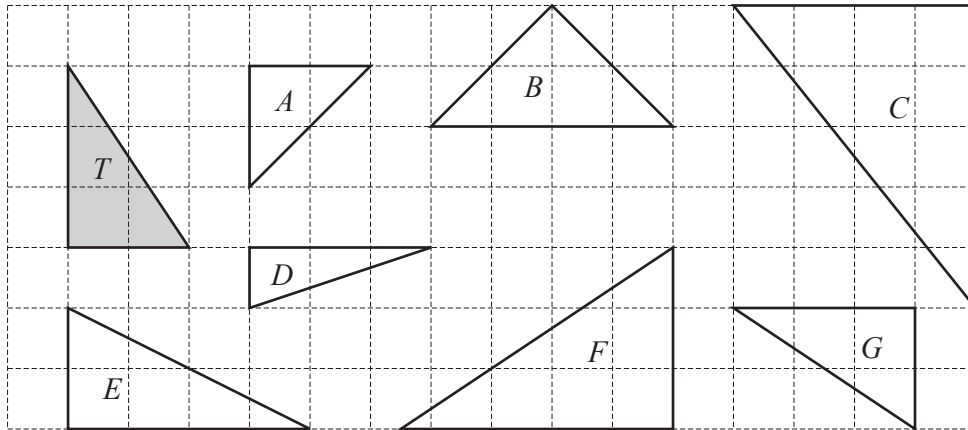

- (i) Write down the letter of the triangle that is congruent to triangle  $T$ .

..... [1]

- (ii) Write down the letter of the triangle that is similar but not congruent to triangle  $T$ .

..... [1]

(c)

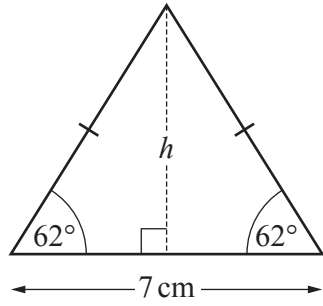

NOT TO SCALE

The diagram shows an isosceles triangle.

(i) Show that the perpendicular height,  $h$ , is 6.58 cm, correct to 3 significant figures.

[3]

(ii) Calculate the area of the triangle.  
Give the units of your answer.

..... [3]

(iii) Kalpit tries to arrange some of these triangles to make a regular polygon with centre  $O$ .

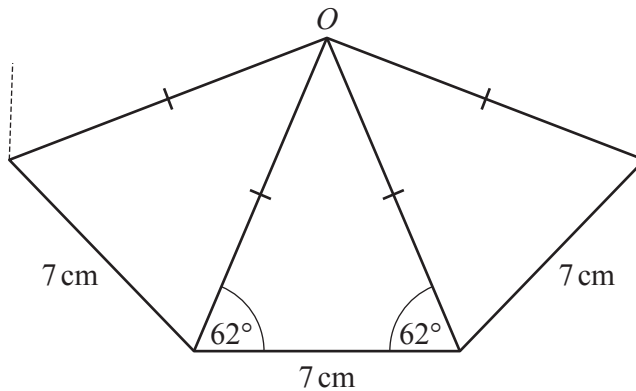

NOT TO SCALE

Show that Kalpit cannot make a regular polygon.

[3]

- 4 (a) A shop sells 58 televisions in one week.  
The bar chart shows the number of televisions that the shop sells on five of the days.

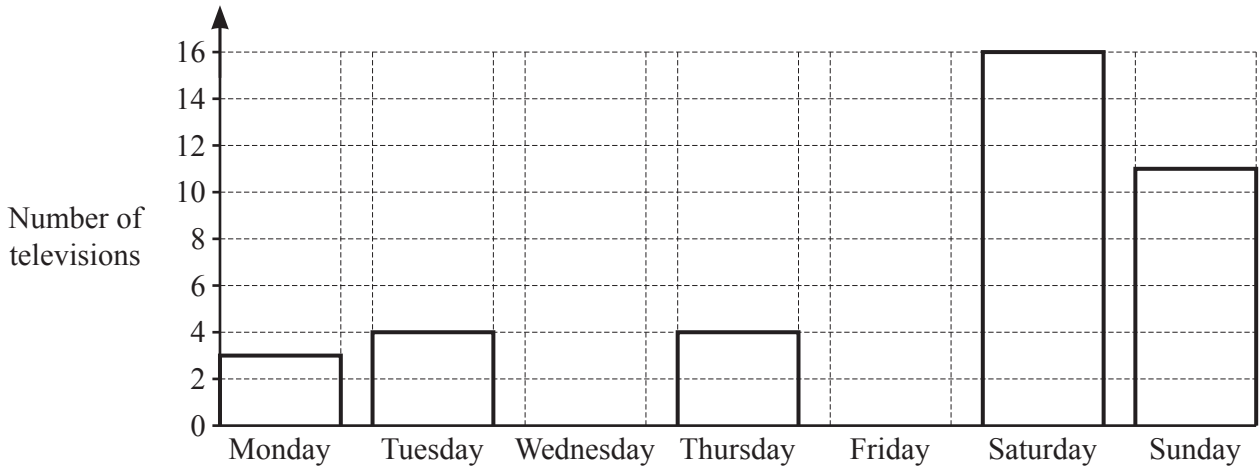

(i) Write down the number of televisions that the shop sells on Monday.  
..... [1]

(ii) Find the fraction of the televisions that the shop sells on Sunday.  
..... [1]

(iii) The number of televisions that the shop sells on the other two days is in the ratio  
Wednesday : Friday = 2 : 3.

Complete the bar chart.

(iv) Write down the mode.  
..... [4]  
..... [1]

- (b) A television has a price of \$550.  
This price is reduced by 4%.

Calculate the new price of this television.

\$ ..... [2]



(c) The scatter diagram shows the prices of different sized televisions.

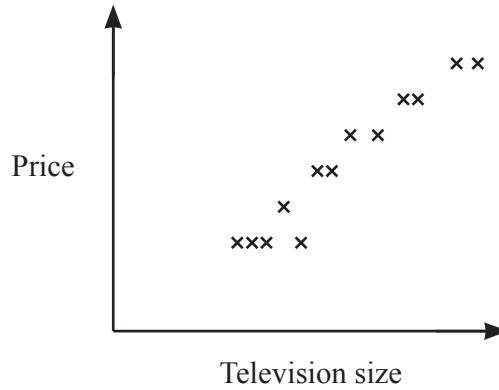

Write down the type of correlation shown in the scatter diagram.

..... [1]

(d) Hemang buys two televisions.  
The probability that a television is faulty is 0.02 .

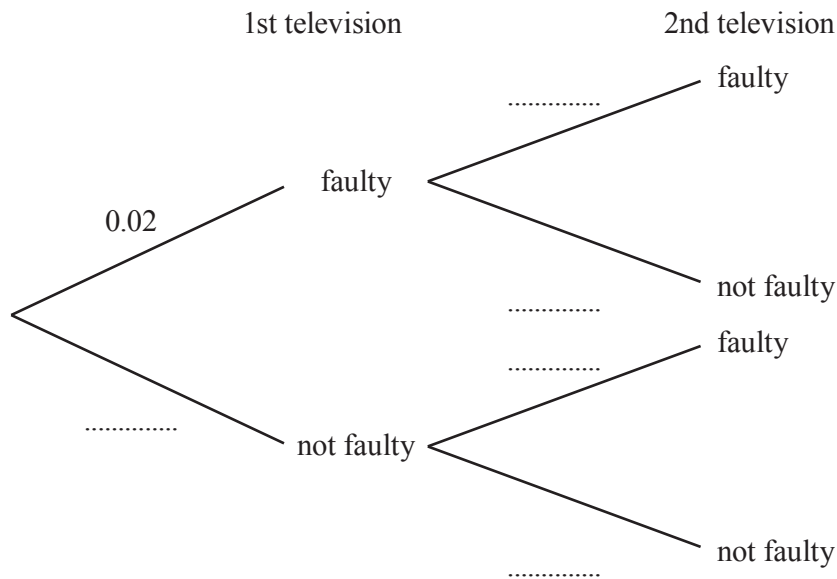

(i) Complete the tree diagram. [2]

(ii) Find the probability that Hemang buys two faulty televisions.  
..... [2]

(iii) The shop sells 4150 televisions in one year.  
Calculate the expected number of faulty televisions.  
..... [1]

5 (a) (i) Complete the table of values for  $y = -x^2 + 5x + 7$ .

$x$	-1	0	1	2	3	4	5	6
$y$			11			11		1

[3]

(ii) On the grid, draw the graph of  $y = -x^2 + 5x + 7$  for  $-1 \leq x \leq 6$ .

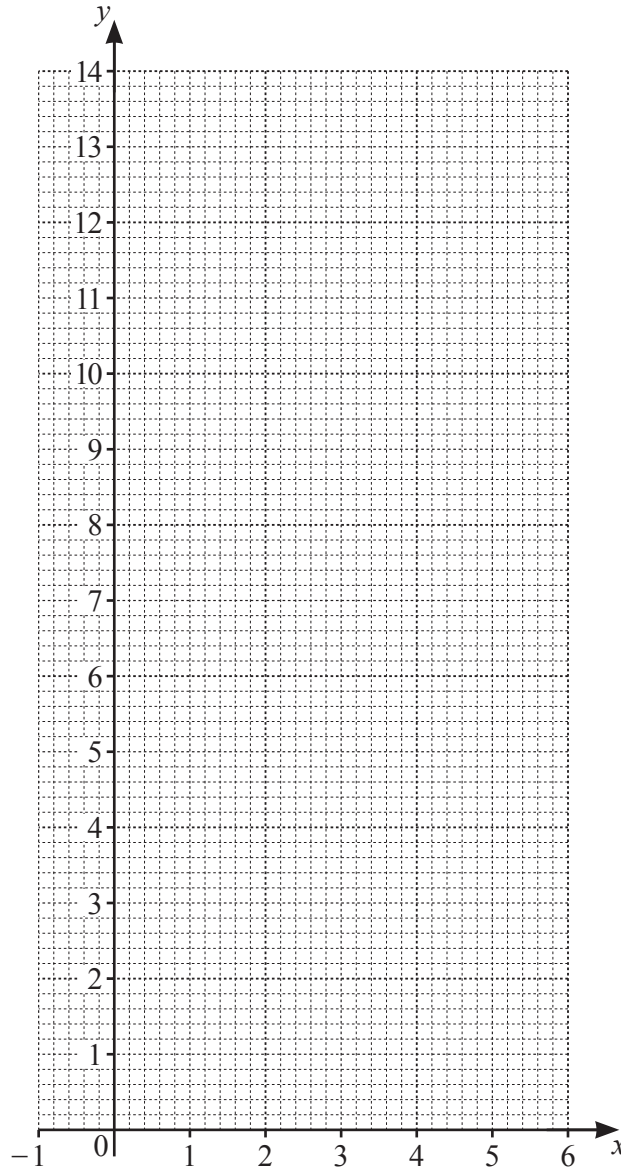

[4]

(iii) (a) Write down the equation of the line of symmetry of the graph.

..... [1]

(b) The points  $(-8, -97)$  and  $(t, -97)$  also lie on the graph of  $y = -x^2 + 5x + 7$ .

Use symmetry to find the value of  $t$ .

$t =$  ..... [1]

(b) Write down the gradient of the line  $y = 9x - 4$ .

..... [1]

(c) Write down the equation of a line parallel to  $y = -5x + 19$ .

$y =$  ..... [1]

(d)

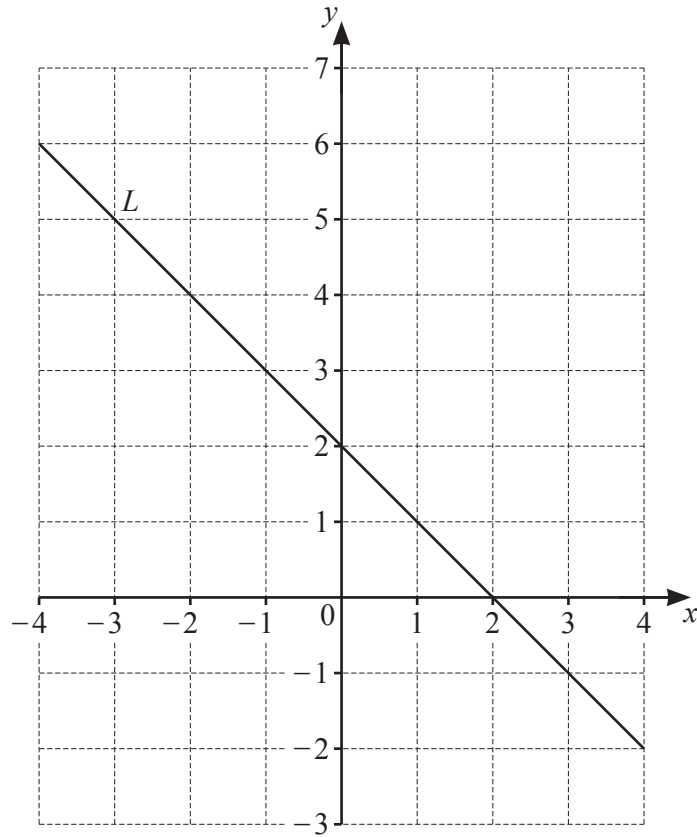

Find the equation of line  $L$  in the form  $y = mx + c$ .

$y =$  ..... [2]

(e) Make  $x$  the subject of the formula  $y = mx + c$ .

$x =$  ..... [2]

- 6 (a) Town  $S$  is 44 km from town  $R$  on a bearing of  $117^\circ$ .
- (i) Using a scale of 1 cm represents 8 km, mark the position of town  $S$ .

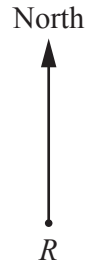

Scale: 1 cm to 8 km

[2]

- (ii) Anvi cycles the 44 km from  $R$  to  $S$ .  
She leaves  $R$  at 13 15 and cycles at a speed of 12 km/h.

Work out the time she arrives at  $S$ .

..... [3]

- (b) A tower has a height of 16 metres.  
When Jai makes a scale drawing of the tower it has a height of 20 cm.

Work out the scale Jai uses, giving your answer in the form  $1 : n$ .

1 : ..... [2]

(c)  $X$ ,  $Y$  and  $Z$  are three towns.

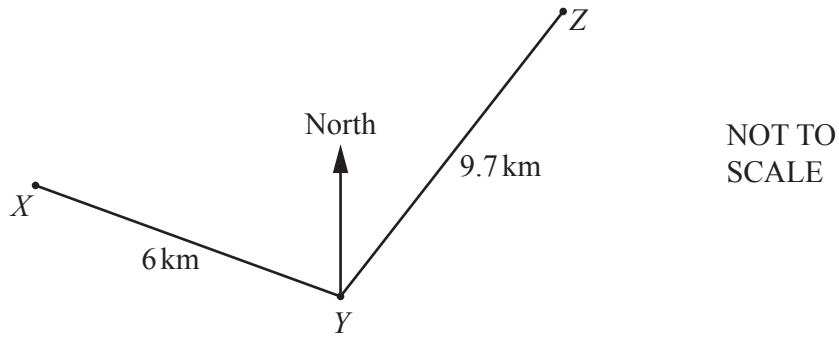

$X$  is on a bearing of  $288^\circ$  from  $Y$ .  
 $Z$  is on a bearing of  $018^\circ$  from  $Y$ .

(i) Show that angle  $XYZ$  is  $90^\circ$ .

[2]

(ii)  $XY = 6$  km and  $YZ = 9.7$  km.

Calculate  $XZ$ .

$XZ = \dots\dots\dots$  km [2]

7 (a)  $P = 3a + 5$

Find the value of  $P$  when  $a = 2$ .

$$P = \dots\dots\dots [1]$$

(b) Solve these equations.

(i)  $7x = -42$

$$x = \dots\dots\dots [1]$$

(ii)  $9(8x - 7) = 72$

$$x = \dots\dots\dots [3]$$

(c)  $5^8 \times 5^k = 5^{-24}$

Find the value of  $k$ .

$$k = \dots\dots\dots [1]$$

(d) Solve the simultaneous equations.

$$-6x - y = 13$$

$$8x + y = -51$$

$$x = \dots\dots\dots$$

$$y = \dots\dots\dots [2]$$

- (e)  $n$  is an integer where  $n > -3$  and  $n \leq 1$ .

Write down all the possible values of  $n$ .

..... [2]

- (f) A boy walks for 35 minutes at  $x$  metres per minute.  
He then runs for  $t$  minutes at 160 metres per minute.

Write down an expression, in terms of  $x$  and  $t$ , for the total distance, in metres, the boy travels.

..... m [2]

- (g)

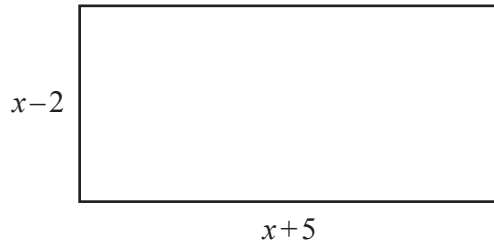

NOT TO  
SCALE

Find an expression for the area of this rectangle.  
Give your answer in the form  $x^2 + ax + b$ .

..... [3]

**Question 8 is printed on the next page.**

- 8 (a) 120 people teach in a university mathematics department. Some information is shown in the table.

	Lecturers	Professors	Total
Part-time		11	
Full-time			
Total			120

One fifth of the people are professors.  
 30% of the people are part-time.

Work out the number of full-time lecturers.

..... [4]

- (b)  $\mathcal{E} = \{\text{children in a school}\}$   
 $F = \{\text{children who like fruit}\}$   
 $V = \{\text{children who like vegetables}\}$

24 children like vegetables but do not like fruit.  
 8 children do not like fruit and do not like vegetables.  
 $n(F \cap V) = 9$   
 $n(F) = 3 \times n(V)$

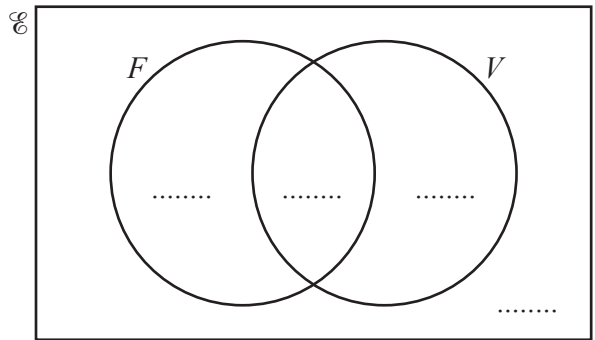

- (i) Complete the Venn diagram. [3]  
 (ii) Work out  $n(F \cup V)$ .

..... [1]

Permission to reproduce items where third-party owned material protected by copyright is included has been sought and cleared where possible. Every reasonable effort has been made by the publisher (UCLES) to trace copyright holders, but if any items requiring clearance have unwittingly been included, the publisher will be pleased to make amends at the earliest possible opportunity.

To avoid the issue of disclosure of answer-related information to candidates, all copyright acknowledgements are reproduced online in the Cambridge Assessment International Education Copyright Acknowledgements Booklet. This is produced for each series of examinations and is freely available to download at [www.cambridgeinternational.org](http://www.cambridgeinternational.org) after the live examination series.

Cambridge Assessment International Education is part of Cambridge Assessment. Cambridge Assessment is the brand name of the University of Cambridge Local Examinations Syndicate (UCLES), which is a department of the University of Cambridge.